

FLENDER COUPLINGS
CATALOG **FLE 10.3**
EDITION 2023 EN

ABM  **TECNA**
the global solution

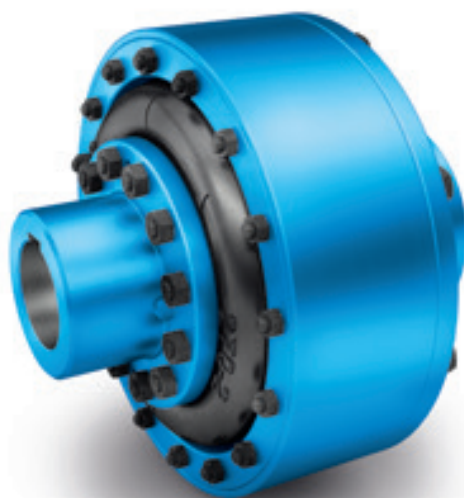

HIGHLY FLEXIBLE COUPLINGS ELPEX

HIGHLY FLEXIBLE COUPLINGS – ELPEX SERIES

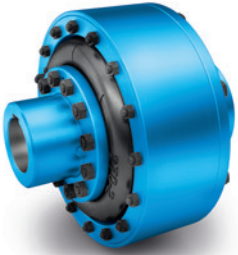

General	12/3
Benefits	12/3
Application	12/3
Design and configurations	12/4
Configuration	12/5
Technical specifications	12/7
<hr/>	
Type ENG	12/8
<hr/>	
Type ENGS – with fail-safe device	12/10
<hr/>	
Types EFG	12/12
<hr/>	
Types EFGS – with fail-safe device	12/14
<hr/>	
Spare and wear parts	12/16
<hr/>	



ELPEX
FLENDER

GENERAL



ELPEX couplings are highly torsionally flexible and free of torsional backlash. Because of their low torsional stiffness and damping capacity, ELPEX couplings are especially suitable for coupling machines with a very non uniform torque pattern. ELPEX couplings are also suitable for connecting machines with high shaft misalignment. Standard ELPEX coupling types are designed as shaft-shaft connections or flange-shaft connections. Application-related types can be implemented on request.

Benefits

The ELPEX coupling is suitable for horizontal and vertical mounting positions or mounting at any required angle. The coupling parts can be arranged as required on the shafts to be connected.

The split flexible rings can be changed without having to move the coupled machines.

The flexible rings are mounted without backlash and give the coupling progressive torsional stiffness, i.e. torsional stiffness increases in proportion to coupling load.

The ELPEX coupling is especially suitable for reversing operation or operation with changing directions of load.

The coupling is delivered preassembled. The flexible rings are completely assembled. On the type ENG, the coupling halves have to be bolted together after the hub has been mounted. On the type EFG, after mounting the coupling hub, only the outer flange has to be connected to the machine.

Outer flanges with different connection dimensions are available for the type EFG.

If the flexible rings are irreparably damaged or worn, the metal parts can rotate freely against one another, they are not in contact with one another.

Application

The ELPEX coupling is available in 9 sizes with a nominal torque of between 1600 Nm and 90000 Nm. The coupling is suitable for ambient temperatures of between -40 °C and +80 °C.

The ELPEX coupling is frequently used for high-quality drives which have to guarantee very long service life in harsh operating conditions.

Examples of applications are mill drives in the cement industry, marine main and secondary drives or drives on large excavators powered by an electric motor or diesel engine.

GENERAL

Design and configurations

The ELPEX coupling's transmission characteristic is determined essentially by the flexible rings. The flexible rings are manufactured from a natural rubber mixture with a multiply fabric lining. The flexible rings are split so that they can be changed without having to move the coupled machines.

The flexible rings are fastened to the hub with a clamping ring and to the outer flange with a clamping ring, using pins and bolts.

On the EFG type, the outer flange is designed with connection dimensions for connection to e.g. a diesel engine flywheel. On ENG types, the outer flange is fitted to a second hub part, which then enables the shaft-shaft connection.

Materials

	Type	Cast iron	Steel
Hub part 1		Grey cast iron EN-GJL-250	Steel
Hub part 2		Steel	Steel
Retaining ring, outer ENG, ENGS		Grey cast iron EN-GJL-250	Steel
Outer flange EFG, EFGS		Grey cast iron EN-GJL-250	Steel

Flexible ring materials

Material/Description	Hardness	Marking	Ambient temperature
Natural rubber	70 ShoreA	Size - 2	-40 ... +80 °C

ELPEX coupling types

Type	Description
ENG	Coupling as shaft-shaft connection
EFG	Coupling as flange-shaft connection
ENGS	as ENG with fail-safe device
EFGS	as EFG with fail-safe device

Further application-specific coupling types are available. Dimension sheets for and information on these are available on request.

The following versions have already been implemented a number of times:

- ELPEX coupling with brake drum, brake disk or flywheel mass
- ELPEX coupling with axial backlash limiter
- ELPEX coupling with adapter
- ELPEX coupling in combination with a safety slip clutch
- ELPEX coupling for engaging/disengaging during stand-still ELPEX coupling as part of a coupling combination

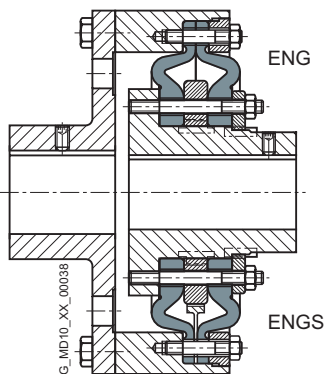

Types ENG/ENGS

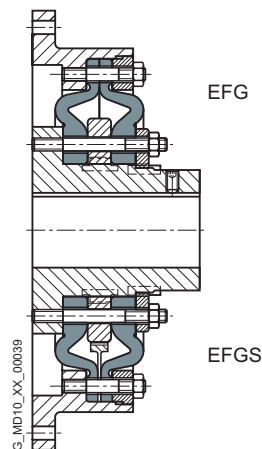

Types EFG/EFGS

Fail-safe device of ELPEX coupling

Types ENGS and EFGS are provided with a fail-safe device. In normal operation the torsion angle of the flexible rings is smaller than the gap between the cams. In normal operation there is no metal-metal contact. If the flexible rings fail, cams transmit the torque from the inner part and outer part. These enable the coupling to be used in emergency mode for a short time. This option is frequently required e.g. in the case of marine drives.

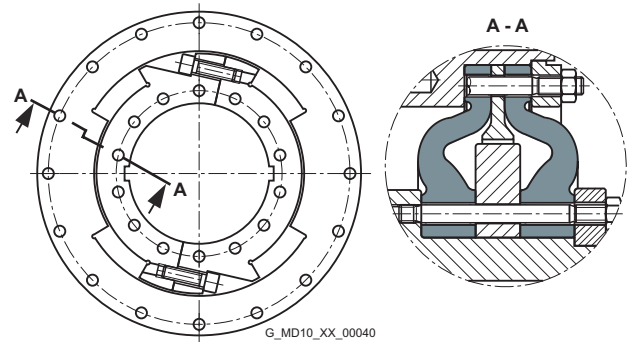

Fail-safe device

Configuration

Coupling selection

The ELPEX coupling is especially suitable for rough operating environments. An application factor lower than that in **Chapter introduction** is therefore sufficient for all applications.

In the case of machines which excite torsional vibration, Flender urgently recommends carrying out a torsional vibration calculation or measuring the coupling load occurring in the drive.

Coupling load in continuous operation

The operating principles of the driving and driven machines are divided into categories and the application factor FB derived from these in accordance with DIN 3990-1.

Examples of torque characteristic in driven machines:

- uniform with moderate shock loads:
Generators, fans, blowers

- non uniform: Reciprocating compressors, mixers, conveyor systems

- very rough: crushers, excavators, presses, mills

Application factor FB	Torque characteristic of the driven machine		
	uniform with moderate shock loads	non uniform	very rough
Electric motors, hydraulic motors, gas and water turbines	1.0	1.3	1.4
Internal-combustion engines	1.3	1.4	1.6

Temperature factor FT		Temperature T_a on the coupling				
Coupling	Elastomer material	-40 up to -30 °C	-30 up to +50 °C	up to 60 °C	up to 70 °C	up to 80 °C
ELPEX	NR	1.1	1.0	1.25	1.40	1.60

NR = Natural rubber mixture

Coupling size $T_{KN} \geq T_N \cdot FB \cdot FT$

GENERAL

Coupling load under maximum and overload conditions

The maximum torque is the highest load acting on the coupling in normal operation.

Maximum torques at a frequency of up to 25 times an hour are permitted and must be lower than the maximum coupling torque. Examples of maximum torque conditions are: Starting operations, stopping operations or usual operating conditions with maximum load.

$$T_{K_{\max}} \geq T_{\text{Max}} \cdot FT$$

Overload torques are maximum loads which occur only in combination with special, infrequent operating conditions. Examples of overload torque conditions are: Motor short circuit, emergency stop or blocking because of component breakage. Overload torques at a frequency of once a month are permitted and must be lower than the maximum overload torque of the coupling. The overload condition may last only a short while, i.e. fractions of a second.

$$T_{K_{OL}} \geq T_{OL} \cdot FT$$

Coupling load due to dynamic torque load

Applying the frequency factor FF, the dynamic torque load must be lower than the coupling fatigue torque.

Dynamic torque load

$$T_{KW} \geq T_W \cdot FT \cdot FF$$

Frequency of the dynamic torque load

$$f_{\text{err}} \leq 10 \text{ Hz frequency factor } FF = 1.0$$

Frequency of the dynamic torque load

$$f_{\text{err}} > 10 \text{ Hz frequency factor } FF = \sqrt{(f_{\text{err}}/10 \text{ Hz})}$$

Checking the maximum speed

For all load situations $n_{K_{\max}} \geq n_{\text{max}}$

Checking permitted shaft misalignment and restorative forces

For all load situations, the actual shaft misalignment must be less than the permitted shaft misalignment.

Checking bore diameter, mounting geometry and coupling design

The check must be made on the basis of the dimension tables. On request, couplings with adapted geometry can be provided.

Checking shaft-hub connection

For any information on this, please refer to **Page E/20**.

Checking low temperature and chemically aggressive environment

The permitted coupling temperature is specified in the Temperature Factor FT table. In the case of chemically aggressive environments, please consult the manufacturer.

Technical specifications

Power ratings of the ELPEX series										
Size	Rated torque	Maximum torque	Overload torque	Fatigue torque	Dynamic torsional stiffness for 100 % load	Stiffness		Permitted shaft misalignment at speed $n = 1500$ rpm		
	T_{KN} Nm	T_{Kmax} Nm	T_{KOL} Nm	T_{KW} Nm		Axial C_a N/mm	Radial C_r mm	Axial ΔK_a mm	Radial ΔK_r mm	Angle ΔK_w °
270	1600	4800	6400	640	22	660	770	2.2	2.2	0.2
320	2800	8400	11200	1120	38	780	910	2.6	2.6	0.2
375	4500	13500	18000	1800	63	970	1130	3	3	0.2
430	7100	21300	28400	2840	97	1160	1350	3.4	3.4	0.2
500	11200	33600	44800	4480	155	1410	1630	3.8	3.8	0.2
590	18000	54000	72000	7200	240	1710	1990	4.2	4.2	0.2
690	28000	84000	112000	11200	365	2060	2390	4.6	4.6	0.2
840	45000	135000	180000	18000	685	2570	2990	5	5	0.2
970	90000	270000	360000	36000	1100	3020	3510	5.5	5.5	0.2

Torsional stiffness and damping

The dynamic torsional stiffness is load-dependent and increases in proportion to capacity utilization. The values specified in the selection table apply to a capacity utilization of 100 %. The following table shows the correction factors for different rated loads.

$$C_{Tdyn} = C_{Tdyn 100\%} \cdot FKC$$

	Load T_N / T_{KN}						
	20%	50%	60%	70%	80%	100%	200%
Correction factor FKC	0.3	0.56	0.65	0.74	0.82	1	1.9

The damping coefficient is $\Psi = 1.1$

Torsional stiffness also depends on the ambient temperature and the frequency and amplitude of the torsional vibration excitation. More precise torsional stiffness and damping parameters on request.

With flexible couplings the manufacturing process of the rubber elements and their aging primarily influence the stiffness value C_{Tdyn} . For this reason calculation must be made with a tolerance for the dynamic stiffness of $\pm 20\%$. The specified damping coefficient Ψ is a minimum value with the result that the damping performance of the coupling corresponds at least to the specified value.

Permitted shaft misalignment

The permitted shaft misalignment depends on the operating speed. As the speed increases, lower shaft misalignment values are permitted. The correction factors for different speeds are specified in the following table. The maximum speed for the respective coupling size must be noted!

$$\Delta K_{perm} = \Delta K_{1500} \cdot FKV$$

	Speed in rpm			
	500	1000	1500	3000
Correction factor FKV	1.6	1.25	1.0	0.7

TYPE ENG

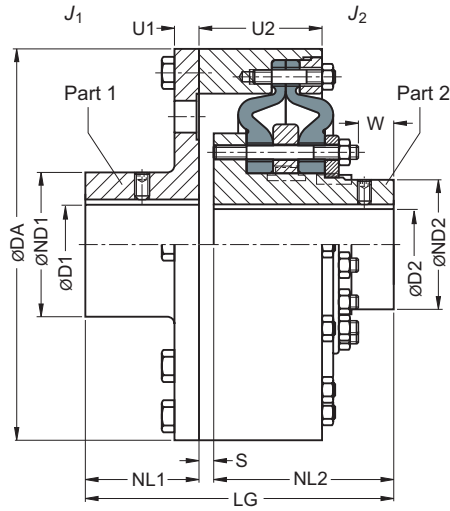

Sizes 270 ... 430

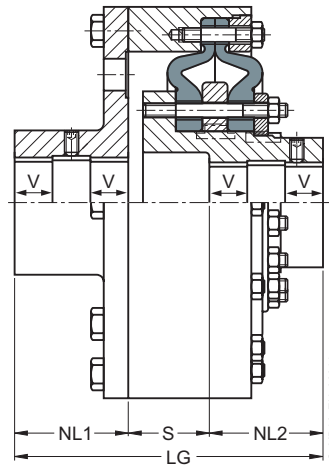

Sizes 500 ... 970

Size	Rated torque T_{KN} Nm	Maximum speed		Dimensions in mm																Mass moment of inertia		Article no. ¹⁾		Weight m kg
		Cast iron n_{Kmax} rpm	Steel n_{Kmax} rpm	Keyway DIN 6885				DA	ND1	ND2	NL1	NL2	S	U1	U2	W	LG	J_1 kgm ²	J_2 kgm ²	Cast iron	Steel			
				D1 min.	D1 max.	D2 min.	D2 max.																	
270	1600	3000	4250	45	80	45	70	270	128	94	80	155	10	14	86	42	245	0.21	0.037	2LC0200-3AF	2LC0200-3AL	29		
320	2800	2500	3600	55	100	55	85	320	160	115	100	180	6	16	97.5	48	286	0.49	0.082	2LC0200-4AF	2LC0200-4AL	50		
375	4500	2100	3100	65	115	65	105	375	184	143	120	205	10	18	111.8	62	335	1.0	0.21	2LC0200-5AF	2LC0200-5AL	80		
430	7100	1900	2650	75	130	75	120	430	208	165	140	235	8	22	126	68	383	2.0	0.37	2LC0200-6AF	2LC0200-6AL	113		
500	11200	1600	2300	90	150	90	150	500	240	202	160	160	112	25	139.7	80	432	3.9	0.85	2LC0200-7AF	2LC0200-7AL	174		
590	18000	1360	2000	100	140	100	170	590	224	230	190	190	130	28	162.7	95	510	8.2	1.7	2LC0200-8AF	2LC0200-8AL	254		
				140	180		224		16.3									350						
690	28000	1200	1650	110	140	110	200	690	288	278	220	220	140	32	175.6	102	580	16.8	3.7	2LC0201-0AF	2LC0201-0AL	370		
				180	210		336		16.9									385						
840	45000	1000	1350	140	180	140	240	840	288	340	280	280	125	42	231	105	685	49	11	2LC0201-1AF	2LC0201-1AL	700		
				180	220		352		50									725						
970	90000	850	1180	160	200	160	280	970	320	384	390	350	350	167	70	290	137	867	104	26	2LC0201-2AF	2LC0201-2AL	1265	
				200	240		448		110										1310					
				240	280				512									115				1410		

Configurable variants ¹⁾

- ØD1 Without finished bore
With finished bore
- ØD2 Without finished bore
With finished bore

¹⁾ To identify complete item numbers specifying the available finish boring options and – if necessary – further order options, please use our configurators on flender.com.

↗ For online configuration on flender.com, click on the item no.

Notes

- The hub diameter of the component part is assigned according to the diameter of the finished bore. Where bore diameters overlap, the component with the smaller hub diameter is always selected.
- Weights and mass moments of inertia apply to cast iron version with maximum bore.
- From size 500, the bores D1 and D2 are each provided with a recess of $D = +1$ mm halfway along the hub. $V \approx 1/3$ NL.

Ordering example

- ELPEX ENG coupling, size 690, cast iron version
- Bore $\varnothing D1 = 180H7$ mm with keyway to DIN 6885 and set screw, the hub diameter $ND1 = 288$ mm is thus assigned
- Bore $\varnothing D2 = 200H7$ mm with keyway to DIN 6885 and set screw, the hub diameter $ND2 = 278$ mm is thus assigned

Article no.: **2LC0201-0AF99-0AA0-Z L2B+M2D**

¹⁾ To identify complete item numbers specifying the available finish boring options and – if necessary – further order options, please use our configurators on [flender.com](https://www.flender.com).

➤ For online configuration on [flender.com](https://www.flender.com), click on the item no.

TYPE ENGS

with fail-safe device

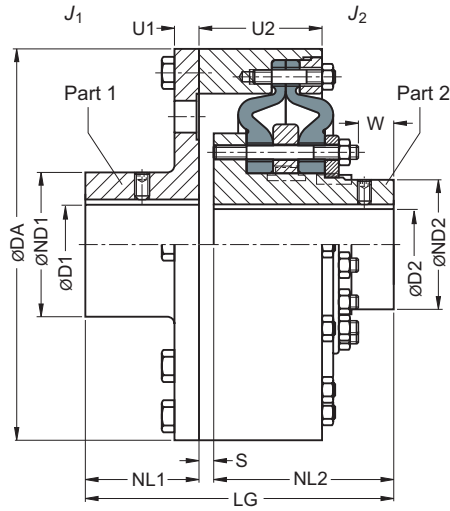

Sizes 270 ... 430

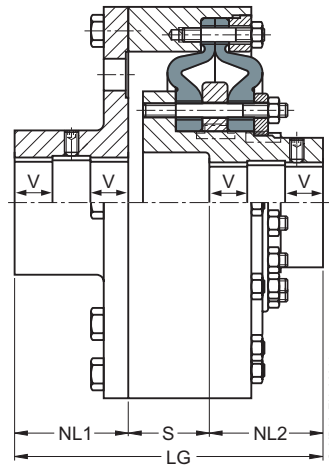

Sizes 500 ... 970

Size	Rated torque T_{KN} Nm	Maximum speed		Dimensions in mm								Mass moment of inertia		Article no. ¹⁾		Weight m kg							
		n_{Kmax} rpm	n_{Kmax} rpm	Type		Keyway DIN 6885		D1 min.	D2 min.	DA	ND1	ND2	NL1	NL2	S		U1	U2	W	LG	J_1 kgm ²	J_2 kgm ²	Type
Cast iron	Steel	D1 max.	D2 max.	Cast iron	Steel																		
270	1600	3000	4250	45	80	45	70	270	128	94	80	155	10	14	86	42	245	0.21	0.037	2LC0200-3AG	2LC0200-3AM	29	
320	2800	2500	3600	55	100	55	85	320	160	115	100	180	6	16	97.5	48	286	0.49	0.082	2LC0200-4AG	2LC0200-4AM	50	
375	4500	2100	3100	65	115	65	105	375	184	143	120	205	10	18	111.8	62	335	1.0	0.21	2LC0200-5AG	2LC0200-5AM	80	
430	7100	1900	2650	75	130	75	120	430	208	165	140	235	8	22	126	68	383	2.0	0.37	2LC0200-6AG	2LC0200-6AM	113	
500	11200	1600	2300	90	150	90	150	500	240	202	160	160	112	25	139.7	80	432	3.9	0.85	2LC0200-7AG	2LC0200-7AM	174	
590	18000	1360	2000	100	140	100	170	590	224	230	190	190	130	28	162.7	95	510	8.2	1.7	2LC0200-8AG	2LC0200-8AM	254	
				140	180		224		16.3									350					
690	28000	1200	1650	110	140	110	200	690	288	278	220	220	140	32	175.6	102	580	16.8	3.7	2LC0201-0AG	2LC0201-0AM	370	
				180	210		336		16.9									385					
840	45000	1000	1350	140	180	140	240	840	288	340	280	280	125	42	231	105	685	49	11	2LC0201-1AG	2LC0201-1AM	700	
				180	220		352		50									725					
970	90000	850	1180	160	200	160	280	970	320	384	390	350	350	167	70	290	137	867	104	26	2LC0201-2AG	2LC0201-2AM	1265
				200	240		448		106										1310				
				240	280				512									110				1350	
				280	320													115				1410	

Configurable variants ¹⁾

- ØD1 Without finished bore
With finished bore
- ØD2 Without finished bore
With finished bore

¹⁾ To identify complete item numbers specifying the available finish boring options and – if necessary – further order options, please use our configurators on flender.com.

↗ For online configuration on flender.com, click on the item no.

Notes

- The hub diameter of the component part is assigned according to the diameter of the finished bore. Where bore diameters overlap, the component with the smaller hub diameter is always selected.
- Weights and mass moments of inertia apply to cast iron version with maximum bore.
- From size 500, the bores D1 and D2 are each provided with a recess of $D = +1$ mm halfway along the hub. $V \approx 1/3$ NL.

Ordering example

- ELPEX ENGS coupling, size 690, cast iron version
- Bore $\varnothing D1 = 180H7$ mm with keyway to DIN 6885 and set screw, the hub diameter $ND1 = 288$ mm is thus assigned
- Bore $\varnothing D2 = 200H7$ mm with keyway to DIN 6885 and set screw, the hub diameter $ND2 = 278$ mm is thus assigned

Article no.: **2LC0201-0AG99-0AA0-Z L2B+M2D**

¹⁾ To identify complete item numbers specifying the available finish boring options and – if necessary – further order options, please use our configurators on [flender.com](https://www.flender.com).

➤ For online configuration on [flender.com](https://www.flender.com), click on the item no.

TYPES EFG

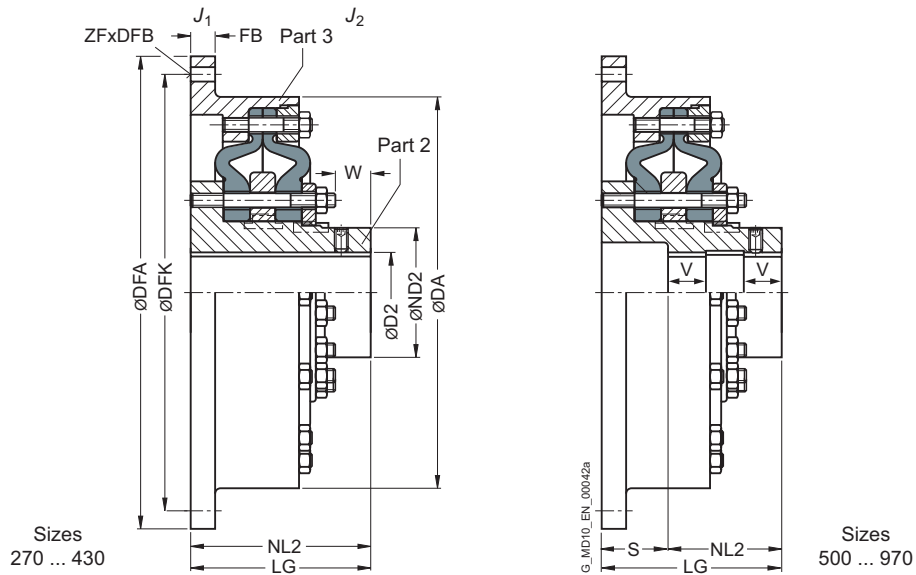

12

Size	Rated torque T_{KN} Nm	Maximum speed		Dimensions in mm										Mass moment of inertia		Article no. ¹⁾		Weight m kg			
		Type Cast iron	Steel	D2 Keyway DIN 6885 min. max.	DA	ND2	NL2	S	W	LG	Flange connection dimensions ²⁾					J_1 kgm ²	J_2 kgm ²		Type	Cast iron	Steel
											DFA	DFK	FB	ZF	DFB						
270	1600	3000	4250	45	70	270	94	155	-	42	155	466.7 ₉₇ ²⁾	438.2 ²⁾	12	8	13	0.47	0.037	2LC0200-3AB2	2LC0200-3AJ2	27
												325 ₆	300	8	14	0.16	2LC0200-3AB1		2LC0200-3AJ1	19	
320	2800	2500	3600	55	85	320	115	180	-	48	180	517.5 ₉₇ ²⁾	489 ²⁾	14	8	13	0.87	0.082	2LC0200-4AB2	2LC0200-4AJ2	42
												392 ₆	360	8	18	0.39	2LC0200-4AB1		2LC0200-4AJ1	33.5	
375	4500	2100	3100	65	105	375	143	205	-	62	205	571.5 ₉₇ ²⁾	542.9 ²⁾	16	6	17	1.5	0.21	2LC0200-5AB2	2LC0200-5AJ2	65
												448 ₆	415	8	18	0.78	2LC0200-5AB1		2LC0200-5AJ1	53	
430	7100	1900	2650	75	120	430	165	235	-	68	235	673.1 ₉₇ ²⁾	641.4 ²⁾	20	12	17	3.4	0.37	2LC0200-6AB2	2LC0200-6AJ2	100
												515 ₆	475	8	22	1.5	2LC0200-6AB1		2LC0200-6AJ1	78	
500	11200	1600	2300	90	150	500	202	160	100	80	260	673.1 ₉₇ ²⁾	641.4 ²⁾	20	12	17	4.0	0.85	2LC0200-7AB2	2LC0200-7AJ2	150
												585 ₆	545	10	22	2.7	2LC0200-7AB1		2LC0200-7AJ1	140	

Configurable variants ¹⁾

- ØD2 Without finished bore
With finished bore

¹⁾ To identify complete item numbers specifying the available finish boring options and – if necessary – further order options, please use our configurators on flender.com.

²⁾ The upper line for the flange connection dimensions complies with standard SAE J620d or DIN 6288.

↗ For online configuration on flender.com, click on the item no.

Size	Rated torque T_{KN} Nm	Maximum speed		Dimensions in mm										Mass moment of inertia		Article no. ¹⁾		Weight m kg			
		Type Cast iron n_{Kmax} rpm	Steel n_{Kmax} rpm	D2 Keyway DIN 6885 min. max.	DA	ND2	NL2	S	W	LG	Flange connection dimensions ²⁾					J_1 kgm ²	J_2 kgm ²		Type Cast iron	Steel	
											DFA	DFK	FB	ZF	DFB						
590	18000	1350	2000	100	170	590	230	190	120	95	310	$\frac{733.4_{g7}^{21}}{692_{j6}}$	$\frac{692.2^{21}}{645}$	24	12	21	7.0	1.7	2LC0200-8AB2	2LC0200-8AJ2	200
												10	26		6.0	2LC0200-8AB1	2LC0200-8AJ1		190		
690	28000	1200	1650	110	200	690	278	220	130	102	350	$\frac{890_{g7}^{21}}{800_{j6}}$	$\frac{850^{21}}{750}$	24	32	17	15	3.7	2LC0201-0AB2	2LC0201-0AJ2	270
												12	26		11	2LC0201-0AB1	2LC0201-0AJ1		250		
840	45000	1000	1350	140	240	840	340	280	115	105	395	$\frac{1105_{g7}^{21}}{960_{j6}}$	$\frac{1060^{21}}{908}$	30	32	21	46	11	2LC0201-1AB2	2LC0201-1AJ2	530
												16	30		32	2LC0201-1AB1	2LC0201-1AJ1		470		
970	90000	850	1180	160	280	970	390	350	155	137	505	$\frac{1385_{g7}^{21}}{1112_{j6}}$	$\frac{1320^{21}}{1051}$	35	24	31	130	26	2LC0201-2AB2	2LC0201-2AJ2	1050
												16	35		76	2LC0201-2AB1	2LC0201-2AJ1		920		

Configurable variants ¹⁾

- ØD2 Without finished bore
With finished bore

Notes

- The hub diameter of the component part is assigned according to the diameter of the finished bore. Where bore diameters overlap, the component with the smaller hub diameter is always selected.
- Weights and mass moments of inertia apply to cast iron version with maximum bore.
- From size 500, the bores D1 and D2 are each provided with a recess of D = +1 mm halfway along the hub. $V \approx 1/3 NL$.
- Notice: The application factor FB in the coupling selection Page 12/5 section must be noted.

Ordering example

- ELPEX EFG coupling, size 430, steel version
- Bore ØD1 = 100H7 mm with keyway to DIN 6885 and set screw, flange to SAE J620d size 21 with DFA = 673.5g7 mm
- Coupling balanced G6.3 in accordance with the half parallel key standard.

Article no.: 2LC0200-6AJ29-0AA0-ZM1N+W02

¹⁾ To identify complete item numbers specifying the available finish boring options and – if necessary – further order options, please use our configurators on flender.com.
²⁾ The upper line for the flange connection dimensions complies with standard SAE J620d or DIN 6288.
 ↗ For online configuration on flender.com, click on the item no.

TYPES EFGS

with fail-safe device

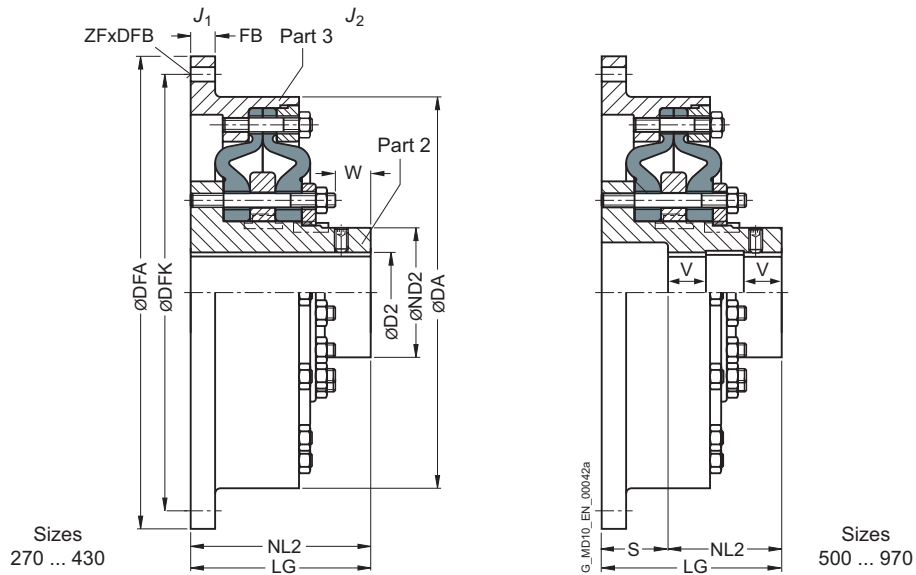

Size	Rated torque T_{KN} Nm	Maximum speed		Dimensions in mm										Mass moment of inertia		Article no. ¹⁾		Weight m kg			
		Type Cast iron	Steel	D2 Keyway DIN 6885 min. max.	DA	ND2	NL2	S	W	LG	Flange connection dimensions ²⁾				J_1 kgm ²	J_2 kgm ²	Type		Cast iron	Steel	
											DFA	DFK	FB	ZF							DFB
270	1600	3000	4250	45	70	270	94	155	-	42	155	466.7 ₉₇ ²⁾	438.2 ²⁾	12	8	13	0.47	0.037	2LC0200-3AC2	2LC0200-3AK2	27
												325 ₆	300		8	14	0.16		2LC0200-3AC1	2LC0200-3AK1	19
320	2800	2500	3600	55	85	320	115	180	-	48	180	517.5 ₉₇ ²⁾	489 ²⁾	14	8	13	0.87	0.082	2LC0200-4AC2	2LC0200-4AK2	42
												392 ₆	360		8	18	0.39		2LC0200-4AC1	2LC0200-4AK1	33.5
375	4500	2100	3100	65	105	375	143	205	-	62	205	571.5 ₉₇ ²⁾	542.9 ²⁾	16	6	17	1.5	0.21	2LC0200-5AC2	2LC0200-5AK2	65
												448 ₆	415		8	18	0.78		2LC0200-5AC1	2LC0200-5AK1	53
430	7100	1900	2650	75	120	430	165	235	-	68	235	673.1 ₉₇ ²⁾	641.4 ²⁾	20	12	17	3.4	0.37	2LC0200-6AC2	2LC0200-6AK2	100
												515 ₆	475		8	22	1.5		2LC0200-6AC1	2LC0200-6AK1	78
500	11200	1600	2300	90	150	500	202	160	100	80	260	673.1 ₉₇ ²⁾	641.4 ²⁾	20	12	17	4.0	0.85	2LC0200-7AC2	2LC0200-7AK2	150
												585 ₆	545		10	22	2.7		2LC0200-7AC1	2LC0200-7AK1	140

Configurable variants ¹⁾

- ØD2 Without finished bore
With finished bore

¹⁾ To identify complete item numbers specifying the available finish boring options and – if necessary – further order options, please use our configurators on flender.com.

²⁾ The upper line for the flange connection dimensions complies with standard SAE J620d or DIN 6288.

↗ For online configuration on flender.com, click on the item no.

Size	Rated torque T_{KN} Nm	Maximum speed		Dimensions in mm										Mass moment of inertia		Article no. ¹⁾		Weight m kg			
		Cast iron n_{Kmax} rpm	Steel n_{Kmax} rpm	D2 Keyway DIN 6885 min. max.	DA	ND2	NL2	S	W	LG	Flange connection dimensions ²⁾					J_1 kgm ²	J_2 kgm ²		Type	Cast iron	Steel
											DFA	DFK	FB	ZF	DFB						
590	18000	1350	2000	100	170	590	230	190	120	95	310	733.4 _{g7} ²⁾	692.2 ²⁾	24	12	21	7.0	1.7	2LC0200-8AC2	2LC0200-8AK2	200
												692 _{g6}	645		10	26	6.0		2LC0200-8AC1	2LC0200-8AK1	190
690	28000	1200	1650	110	200	690	278	220	130	102	350	890 _{g7} ²⁾	850 ²⁾	24	32	17	15	3.7	2LC0201-0AC2	2LC0201-0AK2	270
												800 _{g6}	750		12	26	11		2LC0201-0AC1	2LC0201-0AK1	250
840	45000	1000	1350	140	240	840	340	280	115	105	395	1105 _{g7} ²⁾	1060 ²⁾	30	32	21	46	11	2LC0201-1AC2	2LC0201-1AK2	530
												960 _{g6}	908		16	30	32		2LC0201-1AC1	2LC0201-1AK1	470
970	90000	850	1180	160	280	970	390	350	155	137	505	1385 _{g7} ²⁾	1320 ²⁾	35	24	31	130	26	2LC0201-2AC2	2LC0201-2AK2	1050
												1112 _{g6}	1051		16	35	76		2LC0201-2AC1	2LC0201-2AK1	920

Configurable variants ¹⁾

- ØD2 Without finished bore
With finished bore

Notes

- The hub diameter of the component part is assigned according to the diameter of the finished bore. Where bore diameters overlap, the component with the smaller hub diameter is always selected.
- Weights and mass moments of inertia apply to cast iron version with maximum bore.
- From size 500, the bores D1 and D2 are each provided with a recess of D = +1 mm halfway along the hub. $V \approx 1/3 NL$.
- Notice: The application factor FB in the coupling selection Page 12/5 section must be noted.

Ordering example

- ELPEX EFGS coupling, size 430, steel version
- Bore ØD1 = 100H7 mm with keyway to DIN 6885 and set screw, flange to SAE J620d size 21 with DFA = 673.5g7 mm
- Coupling balanced G6.3 in accordance with the half parallel key standard.

Article no.: 2LC0200-6AK29-0AA0-Z M1N+W02

¹⁾ To identify complete item numbers specifying the available finish boring options and – if necessary – further order options, please use our configurators on flender.com.
²⁾ The upper line for the flange connection dimensions complies with standard SAE J620d or DIN 6288.
 ↗ For online configuration on flender.com, click on the item no.

SPARE AND WEAR PARTS

Flexible rings

Size	➤ Article no. set of flexible rings for a coupling	Weight kg
270	2LC0200-3XV00-0AA0	1.6
320	2LC0200-4XV00-0AA0	2.6
375	2LC0200-5XV00-0AA0	4.4
430	2LC0200-6XV00-0AA0	6.8
500	2LC0200-7XV00-0AA0	9.4
590	2LC0200-8XV00-0AA0	18
690	2LC0201-0XV00-0AA0	36
840	2LC0201-1XV00-0AA0	68
970	2LC0201-2XV00-0AA0	120

Note

- The flexible rings are wear parts. The service life depends on the operating conditions.

Flexible ring screw connection

Size	➤ Article no. set of pins and bolts	
	Type EFG, ENG	EFGS, ENGS
270	2LC0200-3XU00-0AA0	2LC0200-3XW00-0AA0
320	2LC0200-4XU00-0AA0	2LC0200-4XW00-0AA0
375	2LC0200-5XU00-0AA0	2LC0200-5XW00-0AA0
430	2LC0200-6XU00-0AA0	2LC0200-6XW00-0AA0
500	2LC0200-7XU00-0AA0	2LC0200-7XW00-0AA0
590	2LC0200-8XU00-0AA0	2LC0200-8XW00-0AA0
690	2LC0201-0XU00-0AA0	2LC0201-0XW00-0AA0
840	2LC0201-1XU00-0AA0	2LC0201-1XW00-0AA0
970	2LC0201-2XU00-0AA0	2LC0201-2XW00-0AA0

FLENDER COUPLINGS
CATALOG **FLE 10.3**
EDITION 2023 EN



WE
MOVE the
WORLD

Flender GmbH

Alfred-Flender-Straße 77
46395 Bocholt
Germany

Article no.: FLEX-C10003-00-7600

ABM TECNA

Rue des sources 5
6220 FLEURUS
Belgium

+32 71 85 85 00
sales@abm-tecna.be
www.abm-tecna.be

Subject to changes and errors.

The information given in this product catalog includes descriptions and performance features that in specific applications do not always apply in the form described or may change through further-development of the products. The desired performance features are binding only if they are expressly agreed on conclusion of contract. Subject to availability for delivery and to technical changes.